

Thermowells

Fabricated, Screwed Connection

Form 5 per DIN 43 772 • Model SD500G

Form 8 per DIN 43 772 • Model SD800G

Thermometers

Application

The thermowells model SD500G and model SD800G are screw-fitted into the process. They are suitable for low and medium process loads, that might occur as a result of flow, temperature and process pressure influences or vibrations.

An optimized response time design is available for both models due to a reduced wall thickness and a minimized air gap between the inner wall of thermowell and the thermometer stem diameter.

Standard features

Thermowell material

Stainless steel 1.4571 (not with bore size \varnothing 8.5 mm)
Cu-alloy (only with bore size \varnothing 8.5 mm)

Process connection

G $\frac{1}{2}$ B, G $\frac{3}{4}$ B

Instrument connection

SD500G: female thread G $\frac{1}{2}$, G $\frac{3}{4}$
SD800G: male thread G $\frac{1}{2}$ B, G $\frac{3}{4}$ B

Bore size (inner diameter of thermowell)

Design per DIN 43 772:
 \varnothing 7 mm, \varnothing 9 mm, \varnothing 11 mm

Design similar to DIN 43 772, but with quick response time:

\varnothing 6.2 mm, \varnothing 8.2 mm, \varnothing 8.5 mm, \varnothing 10.2 mm

Insertion length U_1

SD500G: 82, 142, 182, 232, 382 mm
SD800G: 73, 110, 170, 260, 410 mm

Total length L

Insertion length + 28 mm

Maximum process temperature ¹⁾

160 °C with thermowell material Cu-alloy
600 °C with thermowell material stainless steel 1.4571

Maximum process pressure (static) ¹⁾

25 bar with thermowell material Cu-alloy
40 bar with thermowell material stainless steel 1.4571

Optional extras

- Other dimensions and materials
- Quality certificates

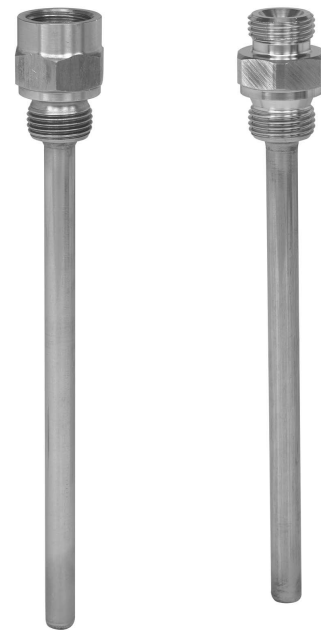

SD500G

SD800G

1) Ratings depends on below parameters:

- Process medium
- Process pressure and temperature
- Flow rate
- Design of thermowell (dimensions, material)

Dimensions

Model SD500G

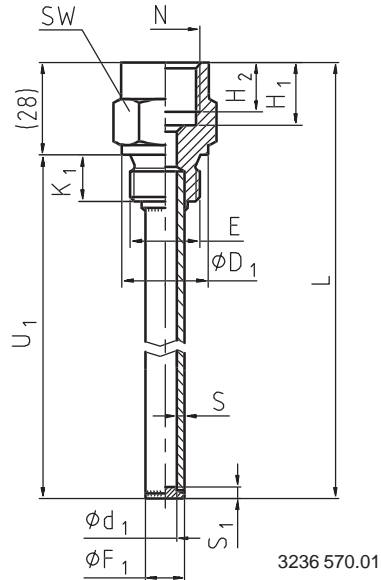

Legend:

- E Process connection
- H₁ Bore depth for female thread
- H₂ Length of female thread
- K₁ Length of male thread
- L Total length
- N Instrument connection
- S Wall thickness
- S₁ Tip thickness
- SW Across flats
- U₁ Insertion length
- Ø d₁ Bore size
- Ø D₁ Diameter of sealing face
- Ø F₁ Thermowell outer diameter

Design per DIN 43772

Material	Dimensions in mm											Weight in kg									
	E	N	Ø d ₁	Ø D ₁	Ø F ₁	H ₁	H ₂	K ₁	S	S ₁	SW	U ₁ = 82 mm	U ₁ = 382 mm								
stainless steel 1.4571	G ½ B	G ½	7	26	12	19	15	14	2.5	3.5	27	0.150	0.330								
			9		14								0.360								
			11		14								0.120	0.280							
	G ¾ B		G ¾	7	32								12	22	17	16	2.5	3.5	32	0.240	0.420
				9									14								0.450
				11									14								0.220
	G ¾ B	G ¾	7	32	12	22	17	16	2.5	3.5	32	0.200	0.380								
			9		14								0.410								
			11		14								0.180	0.330							

Design similar to DIN 43772, optimized response time with responding diameter of the built-in thermometer

Material	Dimensions in mm											Weight in kg									
	E	N	Ø d ₁	Ø D ₁	Ø F ₁	H ₁	H ₂	K ₁	S	S ₁	SW	U ₁ = 82 mm	U ₁ = 382 mm								
stainless steel 1.4571	G ½ B	G ½	6.2	26	8	19	15	14	0.9	1	27	0.120	0.180								
			8.2		10								0.190								
			10.2		12								0.270								
	G ¾ B		G ¾	6.2	32								8	22	17	16	0.9	1	32	0.210	0.270
				8.2									10								0.280
				10.2									12								0.170
	G ¾ B	G ¾	6.2	32	8	22	17	16	0.9	1	32	0.170	0.230								
			8.2		10								0.240								
			10.2		12								0.130	0.200							
	Cu-alloy	G ½ B	G ½	8.5	26	19	15	14	0.75	0.75	27	0.110	0.180								
					32			10			16		32	0.230	0.290						
		G ¾ B	G ¾	32	10	22	17	16	0.75	1	32	0.130	0.200								

Suitable stem lengths of mechanical thermometers

Dial thermometers

Design of connection	Stem length l ₁
S/4/5	l ₁ = L - 10 mm or l ₁ = U ₁ + 18 mm
2	l ₁ = L - 30 mm or l ₁ = U ₁ - 2 mm

Machine glass thermometers

Design of connection	Stem length l ₁
E	l ₁ = L - 10 mm or l ₁ = U ₁ + 18 mm

Dimensions

Model SD800G

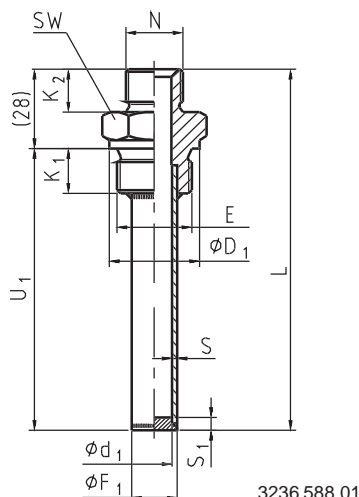

Legend:

- E Process connection
- K₁ Length of male thread
- K₂ Length for instrument connection
- L Total length
- N Instrument connection
- S Wall thickness
- S₁ Tip thickness
- SW Across flats
- U₁ Insertion length
- ∅ d₁ Bore size
- ∅ D₁ Diameter of sealing face
- ∅ F₁ Thermowell outer diameter

Design per DIN 43772

Material	Dimensions in mm										Weight in kg	
	E	N	∅ d ₁	∅ D ₁	∅ F ₁	K ₁	K ₂	S	S ₁	SW	U ₁ = 73 mm	U ₁ = 410 mm
stainless steel 1.4571	G ½ B	G ½ B	7	26	12	14	12	2.5	3.5	27	0.140	0.340
			9		14							0.370
			11		1.5							2.5
	G ¾ B	G ¾ B	7	32	12	16	14	2.5	3.5	32	0.220	0.430
			9		14							0.460
			11		1.5							2.5

Design similar to DIN 43772, optimized response time with responding diameter of the built-in thermometer

Material	Dimensions in mm										Weight in kg		
	E	N	∅ d ₁	∅ D ₁	∅ F ₁	K ₁	K ₂	S	S ₁	SW	U ₁ = 73 mm	U ₁ = 410 mm	
stainless steel 1.4571	G ½ B	G ½ B	6.2	26	8	14	12	0.9	1	27	0.130	0.200	
			8.2		10							0.110	0.180
			10.2		12							0.210	0.280
	G ¾ B	G ¾ B	6.2	32	8	16	14	0.9	1	32	0.210	0.280	
			8.2		10							0.200	0.270
			10.2		12							0.200	0.270

Suitable stem lengths of mechanical thermometers

Dial thermometers

Design of connection	Stem length l ₁
3	l ₁ = L - 12 mm or l ₁ = U ₁ + 16 mm

Machine glass thermometers

Design of connection	Instrument connection	Stem length l ₁
3	G ½	l ₁ = L - 12 mm or l ₁ = U ₁ + 16 mm
	G ¾	l ₁ = L - 8 mm or l ₁ = U ₁ + 20 mm

Ordering information

State: Model / Material / Process connection / Instrument connection / Bore size / Insertion length U_1 / Optional extras required

Specifications and dimensions given in this leaflet are correct at the time of printing.
Modifications may take place and materials specified may be replaced by others without prior notice.



WIKAI Alexander Wiegand GmbH & Co. KG
Alexander-Wiegand-Straße · 63911 Klingenberg
☎ (0 93 72) 132-0 · ☒ (0 93 72) 132-406/414
<http://www.wika.de> · E-mail: info@wika.de