

Bourdon Tube Pressure Gauge Model 213.53, with Liquid Filling and Stainless Steel Case

WIKA Data Sheet PM 02.12



Applications

- Intended for adverse service conditions where pulsating or vibration exists
- Suitable for all gaseous and liquid media that will not obstruct the pressure system or attack copper alloy parts
- Hydraulics
- Compressors
- Shipbuilding industry

Special Features

- Vibration and shock resistant
- Especially sturdy design
- NS 60, 100 approved by German Lloyd and Gosstandard
- Scale ranges up to 0 ... 1000 bar



**Bourdon Tube Pressure Gauge Model 213.53,
radial connection**

Description

Design

EN 837-1

Nominal size

40, 50, 63, 80 and 100 mm

Accuracy class

NS 40: 2.5
NS 50, 63: 1.6
NS 80, 100: 1.0

Scale range

NS 40, 50: 0 ... 1 up to 0 ... 600 bar
NS 63, 80, 100: 0 ... 0.6 up to 0 ... 1000 bar
or other equivalent units of pressure or vacuum.

Working pressure

NS 40, 50, 63: Steady: $\frac{3}{4}$ of scale range
Fluctuating: $\frac{2}{3}$ of scale range
Short time: full scale range

NS 80, 100: Steady: full scale range
Fluctuating: 0.9 x full scale range
Short time: 1.3 x full scale range

Operating Temperature

Ambient: -20 ... +60 °C
Medium: +60 °C maximum

Temperature effect

When temperature of the pressure element deviates from reference temperature (+20 °C):
max. ± 0.4 %/10 K of the span.

Ingress protection

IP 65 (EN 60 529 / IEC 529)

Pressure connection

Material: Cu-alloy
Lower mount, centre back mount or lower back mount
NS 40: G $\frac{1}{8}$ B, 14 mm flats
NS 50, 63: G $\frac{1}{4}$ B, 14 mm flats
NS 80, 100: G $\frac{1}{2}$ B, 22 mm flats

Pressure element

NS 40, 50, 63, 80:

< 60 bar: Cu-alloy, C-type, soft soldered

≥ 60 bar: Cu-alloy, helical type, soft soldered

NS 100:

< 100 bar: Cu-alloy, C-type, soft soldered

≥ 100 bar: stainless steel 1.4571, helical type, brazed

Movement

Cu-alloy

NS 80: Cu-alloy, wear parts argentan

Dial

NS 40, 50, 63: white plastic, with pointer stop pin

NS 80, 100: white aluminium

With black lettering

Pointer

NS 40, 50, 63: black plastic

NS 80, 100: black aluminium

Window

Clear plastic

Case

Natural finish stainless steel

O-Ring seal between case and entry stem

Pressure relief in case top

Ranges ≤ 0 ... 16 bar with case venting provision

Bezel ring

Triangular bezel, roll formed, glossy finish stainless steel

Liquid filling

Glycerine 99,7 %

Optional extras

- NS 50, 63: stainless steel pressure system (model 233.53)
- NS 63, 100: internal pressure compensation
- NS 100: zero point adjustment in front
- Medium temperature to 100°C with special soft solder
- 3-hole panel mounting flange, stainless steel (back entry only (not NS 40))
- 3-hole surface mounting flange, stainless steel (not NS 40)
- with clamp (back entry only)

Dimensions in mm

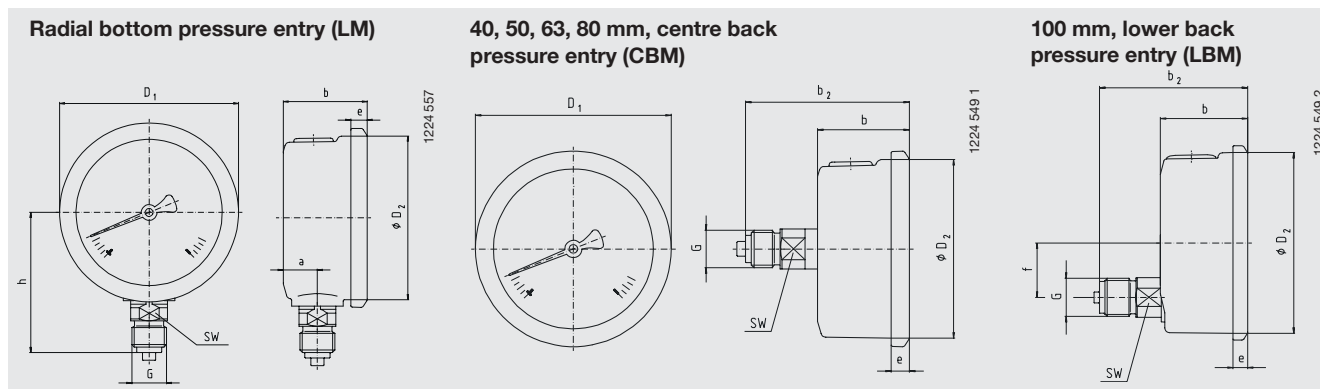

| NS | a | b ₁ ± 0,5 | b ₂ ± 1 | D ₁ | D ₂ | e | f | G | h ± 1 | SW | Weight in kg |
|-----|------|----------------------|--------------------|----------------|----------------|-----|----|---------|-------|----|--------------|
| 40 | 9.5 | 30 | 50 | 46.5 | 40 | 6 | - | G 1/8 B | 40 | 14 | 0.10 |
| 50 | 12 | 30 | 55 | 55 | 50 | 5.5 | - | G 1/4 B | 48 | 14 | 0.15 |
| 63 | 13 | 32 | 56 | 68 | 62 | 6.5 | - | G 1/4 B | 54 | 14 | 0.21 |
| 80 | 15.8 | 43.5 | 78 | 83.6 | 80 | 5 | - | G 1/2 B | 76 | 22 | 0.39 |
| 100 | 15.5 | 48 | 81.5 | 107 | 100 | 8 | 30 | G 1/2 B | 87 | 22 | 0.80 |

Standard pressure entry with parallel thread and sealing to EN 837-1 / 7.3

Ordering information

Pressure gauge model / Nominal size / Scale range / Size of connection / Optional extras required

Specifications and dimensions given in this leaflet represent the state of engineering at the time of printing. Modifications may take place and materials specified may be replaced by others without prior notice.



WIKAL Alexander Wiegand GmbH & Co. KG
 Alexander-Wiegand-Straße 30
 63911 Klingenberg/Germany
 Phone (+49) 93 72/132-0
 Fax (+49) 93 72/132-406
 E-Mail info@wika.de
 www.wika.de