

All stainless steel safety gauges for ultra high pressures according to EN 837-1/S3

Nominal size ND 100
With or without contacts

Connection position bottom, radial



Description

All stainless steel pressure gauges are ideal for harsh conditions and the resulting high demands on pressure measurement in test benches, machine and apparatus construction. Resistance to aggressive media and environments is achieved by using high-grade materials such as stainless steel and NiSpan for the measuring system.

Glycerine filling provides wear-protection for the measuring system through damping, in case of pulsating pressures and mechanical vibrations. The measuring system is of accuracy class 1.0 and 1.6 respectively, has overrange protection up to 1.3 times the max. rating and can be loaded up to the full scale value.

The execution of the pressure gauges comprises a solid front between measuring system and dial, laminated safety glass, blow-out back (acc. to EN 837-1/S3) and a reduction in the diameter of the pressure channel.

The case and other components are made of stainless steel.

Features

- Measuring system of high corrosion-resistant materials
- All stainless steel version
- Accuracy class 1.6
- Fulfils highest safety requirements according to EN 837-1/S3 for version with blow out back
- No indication vibrations and a long durability for filled versions
- Different limit switch contacts possible
- Protection type IP65

Measuring ranges

0 ... 2500 bar to 0 ... 4000 bar

Applications

Machine and apparatus constructions,
High pressure test benches,
Pumps

Models: P1701, P1715

Technical data

Models	P1701	P1715	Options
Nominal size	100		
Symbol			
Accuracy class to EN 837-1	1.6		
Ranges	0 ... 2500bar to 0...4000 bar		
Applications	Constant load: 3/4 x full scale value Dynamic load: 2/3 x full scale value Short time: overload capacity 1.1x		full scale value 0.9 x full scale value, overload capacity 1.3 x
Case	1.4301 with blow-out back, solid front		
Bezel	Stainless steel 1.4301 bayonet ring		Front flange
Window	Laminated safety glass		
Dial	Aluminium white, black imprint		Dual scale
Pointer	Aluminium, black		
Movement	Stainless steel		
Measuring element	<3000 bar Stainless steel, ≥ 3000 bar NiSpan C		Special alloy
Connection - position - thread	Stainless steel 316L radial bottom M 16 x 1.5 female with cone 60°;		Other on request
Temperatures - Medium - Ambient	Tmin. -20°C, Tmax. 80°C Tmin. -25°C, Tmax. 60°C		
Temperature coefficient	0,4%/10K with deviation of reg. temperature of 20°		
Liquid filling	none, instrument is fillable		Glycerine filling
Protection	IP 65 EN 60 529/IEC 529		
Throttle screw	stainless steel 0,6		others on request
Electrical contacts	None	Magnet snap action contact, inductive for EEx or for SPS with switching amplifier	
Number of contacts	None	1 to 3	
Electrical connection	None	Junction box right side bottom direction, 6 clamps + PE, diameter max 2,5mm ²	
Weight	1.1 kg	1.6 kg	

Dimensions

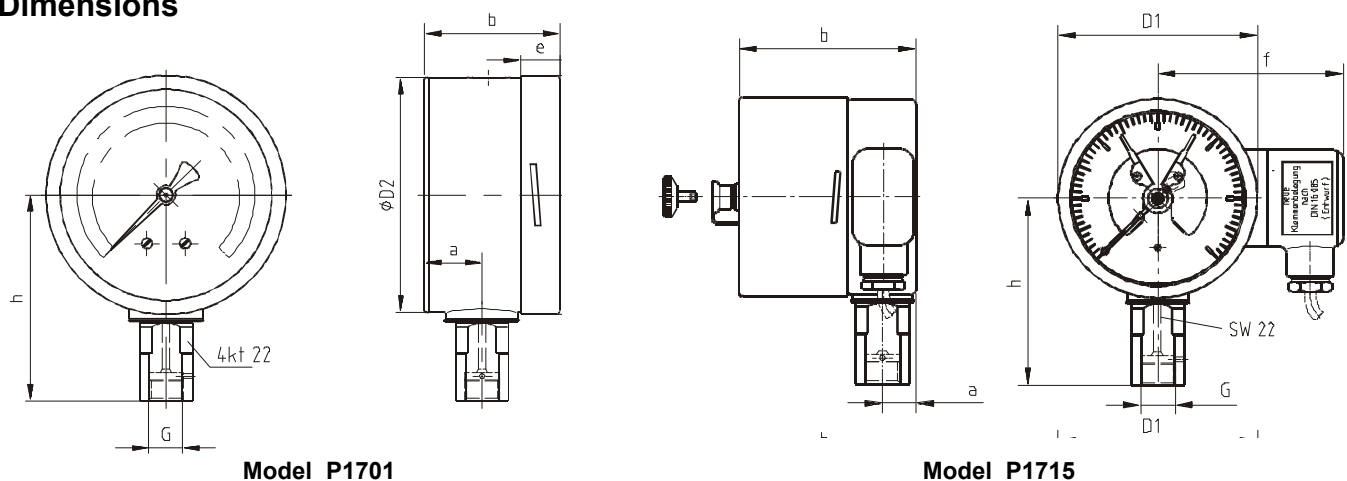

model	Dimensions [mm]								
	a	b	D1	D2	f	e	G	h ±1	SW
P1701	24	57,5	101	100	--	17,5	M16x1,5	87	22
P1715	24	97	101	100	94	55	M16x1,5	87	22

Modifications reserved

All stainless steel safety gauges for ultra high pressures according to EN 837-1/S3

Nominal size ND 100
With or without contacts

Connection position bottom, radial



Description

All stainless steel pressure gauges are ideal for harsh conditions and the resulting high demands on pressure measurement in test benches, machine and apparatus construction. Resistance to aggressive media and environments is achieved by using high-grade materials such as stainless steel and NiSpan for the measuring system.

Glycerine filling provides wear-protection for the measuring system through damping, in case of pulsating pressures and mechanical vibrations. The measuring system is of accuracy class 1.0 and 1.6 respectively, has overrange protection up to 1.3 times the max. rating and can be loaded up to the full scale value.

The execution of the pressure gauges comprises a solid front between measuring system and dial, laminated safety glass, blow-out back (acc. to EN 837-1/S3) and a reduction in the diameter of the pressure channel.

The case and other components are made of stainless steel.

Features

- Measuring system of high corrosion-resistant materials
- All stainless steel version
- Accuracy class 1.6
- Fulfils highest safety requirements according to EN 837-1/S3 for version with blow out back
- No indication vibrations and a long durability for filled versions
- Different limit switch contacts possible
- Protection type IP65

Measuring ranges

0 ... 2500 bar to 0 ... 4000 bar

Applications

Machine and apparatus constructions,
High pressure test benches,
Pumps

Models: P1701, P1715

Technical data

Models	P1701	P1715	Options
Nominal size	100		
Symbol			
Accuracy class to EN 837-1	1.6		
Ranges	0 ... 2500bar to 0...4000 bar		
Applications	Constant load: 3/4 x full scale value Dynamic load: 2/3 x full scale value Short time: overload capacity 1.1x		full scale value 0.9 x full scale value, overload capacity 1.3 x
Case	1.4301 with blow-out back, solid front		
Bezel	Stainless steel 1.4301 bayonet ring		Front flange
Window	Laminated safety glass		
Dial	Aluminium white, black imprint		Dual scale
Pointer	Aluminium, black		
Movement	Stainless steel		
Measuring element	<3000 bar Stainless steel, ≥ 3000 bar NiSpan C		Special alloy
Connection - position - thread	Stainless steel 316L radial bottom M 16 x 1.5 female with cone 60°;		Other on request
Temperatures - Medium - Ambient	Tmin. -20°C, Tmax. 80°C Tmin. -25°C, Tmax. 60°C		
Temperature coefficient	0,4%/10K with deviation of reg. temperature of 20°		
Liquid filling	none, instrument is fillable		Glycerine filling
Protection	IP 65 EN 60 529/IEC 529		
Throttle screw	stainless steel 0,6		others on request
Electrical contacts	None	Magnet snap action contact, inductive for EEx or for SPS with switching amplifier	
Number of contacts	None	1 to 3	
Electrical connection	None	Junction box right side bottom direction, 6 clamps + PE, diameter max 2,5mm ²	
Weight	1.1 kg	1.6 kg	

Dimensions

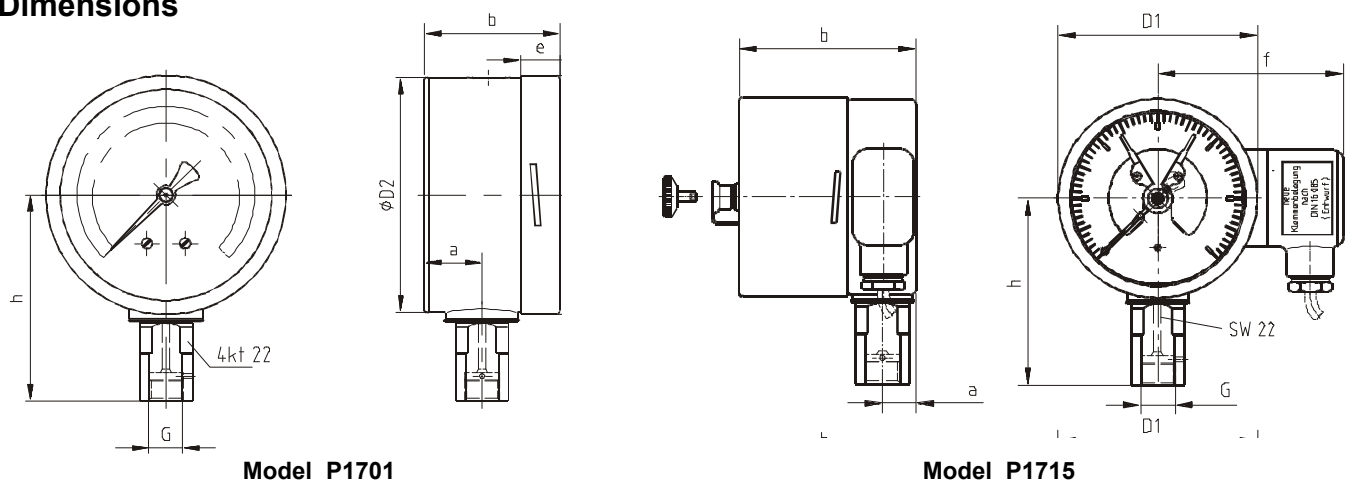

model	Dimensions [mm]								
	a	b	D1	D2	f	e	G	h ±1	SW
P1701	24	57,5	101	100	--	17,5	M16x1,5	87	22
P1715	24	97	101	100	94	55	M16x1,5	87	22

Modifications reserved