

Compression force transducers with small dimensions for measurements in welding guns/ measurements in gaps



Description

These hydraulic load cells measure and indicate forces directly for a reasonable price. The whole unit (load cell and measuring device) works on the hydraulic principle.

In accordance with the surface area of the piston, the force acting on it is transferred to the hydraulic fluid and from there via the connecting pipe to the measuring instrument.

The straightforward relationship between the pressure, force and piston surface area enables the scale of the measuring instrument to be graduated in a variety of units, e.g. kN, kg, t, m³ or litres.

Maximum piston stroke is 0.5 mm.

For precise conversion of force into pressure the force must act vertically and centred on the piston which must not be subject to lateral forces.

The load cells are unsuited, or suited only to a limited extent, to the measurement of impact or acceleration. Provided that the frequency is not too high, oscillating forces can also be measured with hydraulic load cells. In such case a measuring unit with a rather large working range is advisable in the interests of prolonging service life.

Note

Hydraulic measuring devices are filled with hydraulic fluid in a vacuum environment. For this reason a guarantee of proper functioning is only given on fully assembled units. Sealing glands must not be loosened or removed.

Features

- for compression forces
- for force measurement in welding brackets
- Ambient temperature -20 to 60°C
- Stainless steel casing and piston
- Accuracy 1.6% of end scale value when used with pressure measuring instruments class 1.6 and 23°C
- Maximum piston stroke 0.5 mm
- Operation without power supply

Measuring Range

- 250 ... 36 kN

Applications

- Plant engineering
- Production lines
- Measuring and test equipment
- Special mechanical engineering applications

Model: F1101, F1102

Technical data

Model	F1101	F1102	Options
Nominal size	ND 6		
Accuracy	1.6% of end scale value when used with pressure measuring devices class 1.6 and reference temperature 23°C		
Limit load	100% F_{nom}		
Breaking load	> 130% F_{nom}		
Combined error	$\pm 1.6\%$ of F.S.		
Nominal deflection	< 0.5 mm		
Nominal temperature range	-10 ... +50°C		
Protection type	IP 65		
Case	Stainless steel	Plastic-disc (for welding brackets)	
Piston	Stainless steel	Plastic (for welding brackets)	
Connecting line	-connecting adapter L = 50 mm		- connecting adapter L = 100 mm - flexible tube, 1.4571 with spiral steel jacket \varnothing 7mm, of 1.4301 max. length = 1 m.
Pressure measuring device	-Nominal diameter 63 mm in die-cast brass Model P1515,		- Max.-indicating pointer - Pressure sensors model P3249
Hydraulic fluid	silicone oil, FFI.-No. 2		
Dimensions	see dimensional drawing		

Measuring range		Pressure range on measuring device in bar Model P1515 or Model P3249	The load cell size indicates the surface area of the piston in cm ²
Model F1101 ND 6 [kN]	Model F1102 ND 6 [N]		
0,25	250	0 ... 4,0	
0,6	600	0 ... 10,0	
1,0	1000	0 ... 16,0	
1,6	1600	0 ... 25,0	
2,5	2500	0 ... 40,0	
6,0	6000	0 ... 100,0	
10,0	10000	0 ... 160,0	
16,0	16000	0 ... 250,0	
20,0	20000	0 ... 315,0	
25,0	25000	0 ... 400,0	
36,0	36000	0 ... 600,0	

Construction A

Hydraulic force measuring device, consisting of a force transmitter model F1101 ND 6, connecting adapter (L=50 mm) and pressure gauge model P1515 ND 63.

Dimensions:

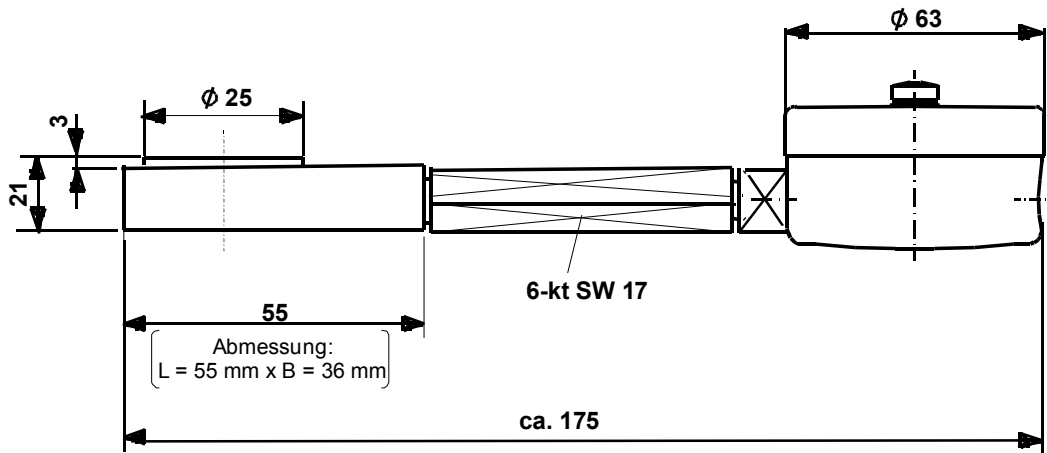

Construction B

Hydraulic force measuring device consisting of a force transmitter model F1102 ND 6, connecting adapter (L=50 mm) and pressure transmitter model P3249.

Dimensions:

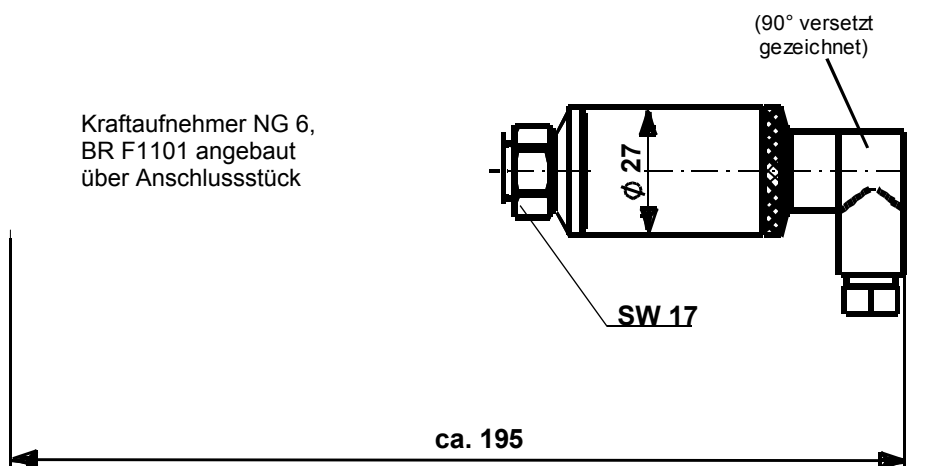

Subject to technical changes